

INSTALLATION SHEET Ford Flareside '04 -

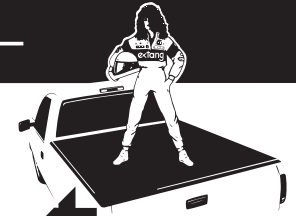

extang

CLASSIC
PLATINUM & BLACKMAX™

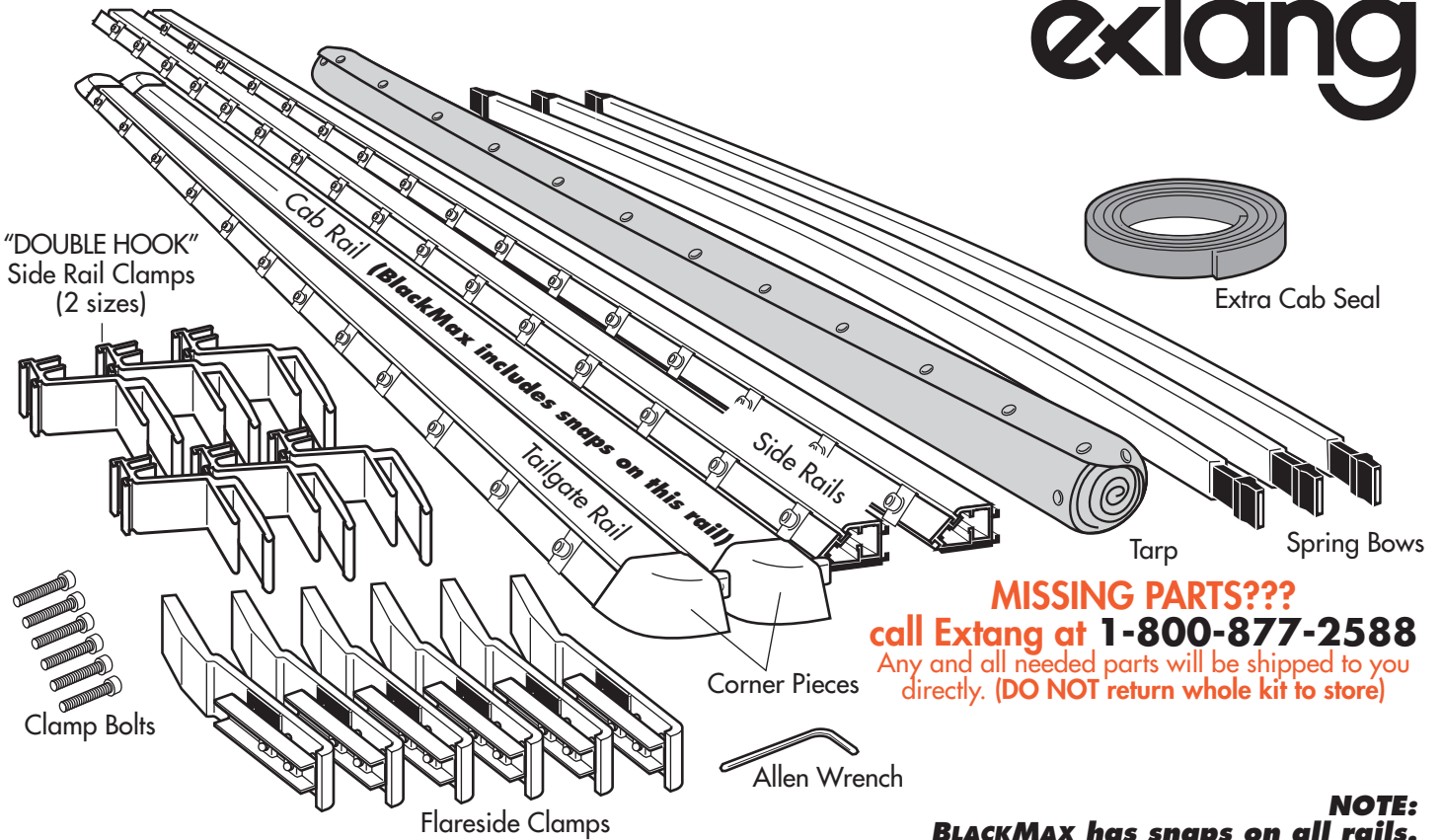

MISSING PARTS???
call Extang at **1-800-877-2588**
Any and all needed parts will be shipped to you directly. (DO NOT return whole kit to store)

NOTE:
BLACKMAX has snaps on all rails.

PARTS INCLUDED IN YOUR KIT. You may want to lay them out in this manner for accessibility.

1

Wash truck bed.

2

Foam has NO adhesive to touch truck finish.

Remove paper tape from all rails. Discard properly.

3 For Classic Platinum Only (This step does not apply to BlackMax)

Depress the ClickLock™ release and remove one corner from cab rail.

Feed tarp dowel into cab rail. (NOTE: For easiest feeding action, place tarp on a flat smooth surface, and keep dowel straight while feeding into cab rail. Caution, pavement may scuff tarp.)

Reinsert corner piece into cab rail until it "clicks" and locks into place.

4

Off the truck bed, connect the end rails to the two side rails utilizing the ClickLock™ clips.

extang
Stands for Quality

Extang Corporation
1901 E. Ellsworth Rd.
Ann Arbor, MI 48108
734 677-0444, Fax: 734 677-8409

Visit us at:
www.extang.com
Item No. 0143-0105 RH Printed in U.S.A.

5

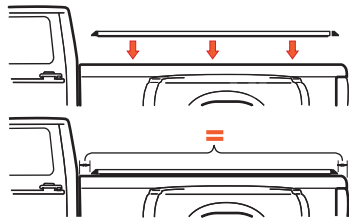

Place the rail assembly over the side of the truck box. Center rails evenly between cab and tailgate. (NOTE: Some applications have hard rubber risers (square rubber pad.) A riser must go toward tailgate. Some applications will have a riser at both ends, (most have no riser).

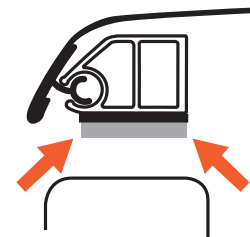
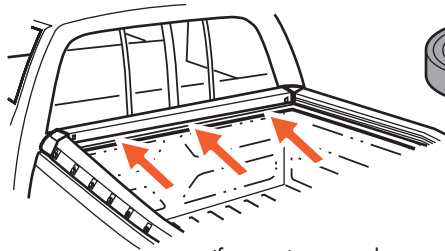

If a gap is present between the cab rail and truck bed, apply extra cab rail foam seal to the bottom of the existing cab rail seal.

6

Note: For over-the-rail bed liners first refer to Diagrams A and B below.

Clamp Spacing (Same for each side) See the stickers located on each side rail for clamp position, or refer to the dimensions given below. Note: Use clamp intended for each position.—Remove stickers after installation.

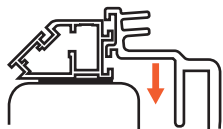

Insert side rail clamp all the way into rail.

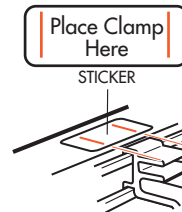
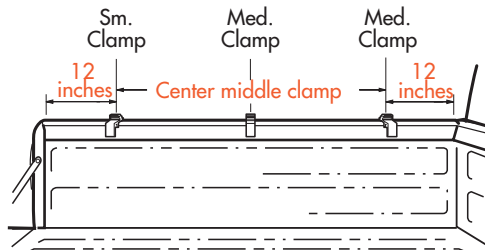
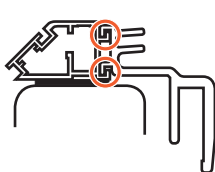

7

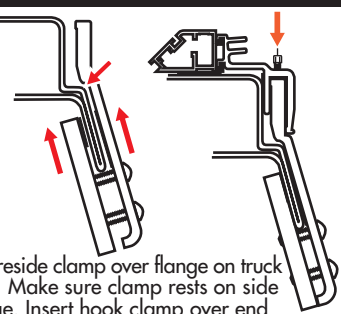

Insert flareside clamp over flange on truck sidewall. Make sure clamp rests on side wall ridge. Insert hook clamp over end and secure with clamp bolt.

8

Insert bow onto top or bottom peg. (Top peg for performance, Bottom for good looks.)

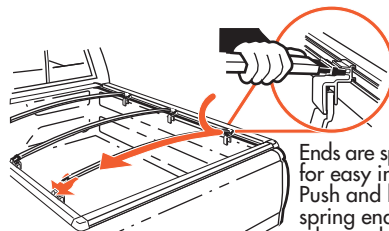

Ends are spring loaded for easy installation. Push and hold on spring end and let the other end slide on with the spring action.



SPECIAL FEATURE: Two pegs offer two height adjustments.

Note: Bow End does not fit between pegs.



Do Not Place Between the Pegs

9

Start at Corners

Attach tarp by starting at the corners, and snap in place.

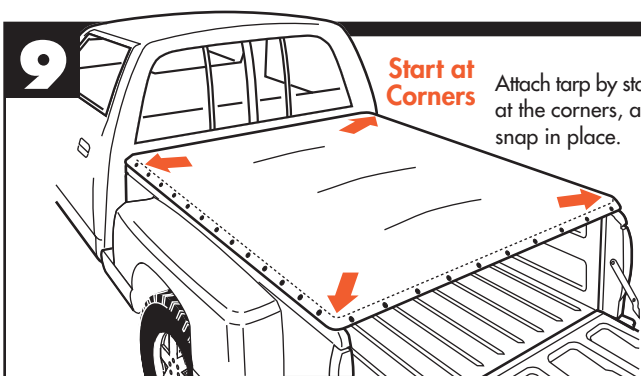

SPECIAL FEATURE Weather-adjustable Snaps

Studs Down

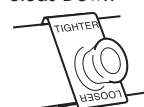

SUMMER SETTING Takes up slack in tarp caused by warm weather.

Slides Off



Rotate 180°



WINTER SETTING Allows more slack in tarp for cold temperatures.

Studs Up

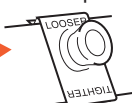

For an OVER-THE-RAIL Bedliner

DIAGRAM

A

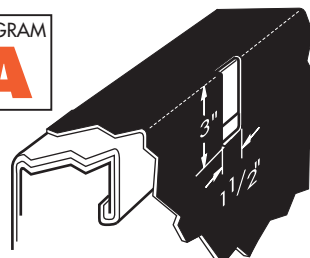

For each clamp mark on your bedliner a 1-1/2" x 3" hole as shown above. Remove clamp. Cut holes in bedliner. Reinsert side rail clamp. Return to step 6.

DIAGRAM

B

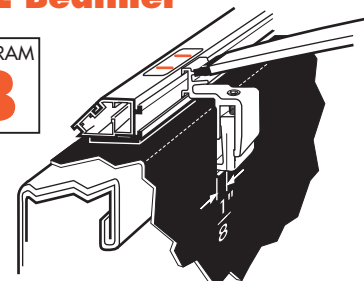

Side rail clamped to bed with bow attached.

EASY USE OF TRUCK BED

Tarp may be rolled up and secured with Velcro® for bulk hauling



Extang Corporation, 1901 E. Ellsworth Rd., Ann Arbor, MI 48108, 734 677-0444, Fax: 734 677-8409, Visit us at: www.extang.com