

INSTALLATION SHEET Ford Flareside '04-

TUFF TONNO™

extang
AMERICA'S BEST
SELLING TONNEAUS

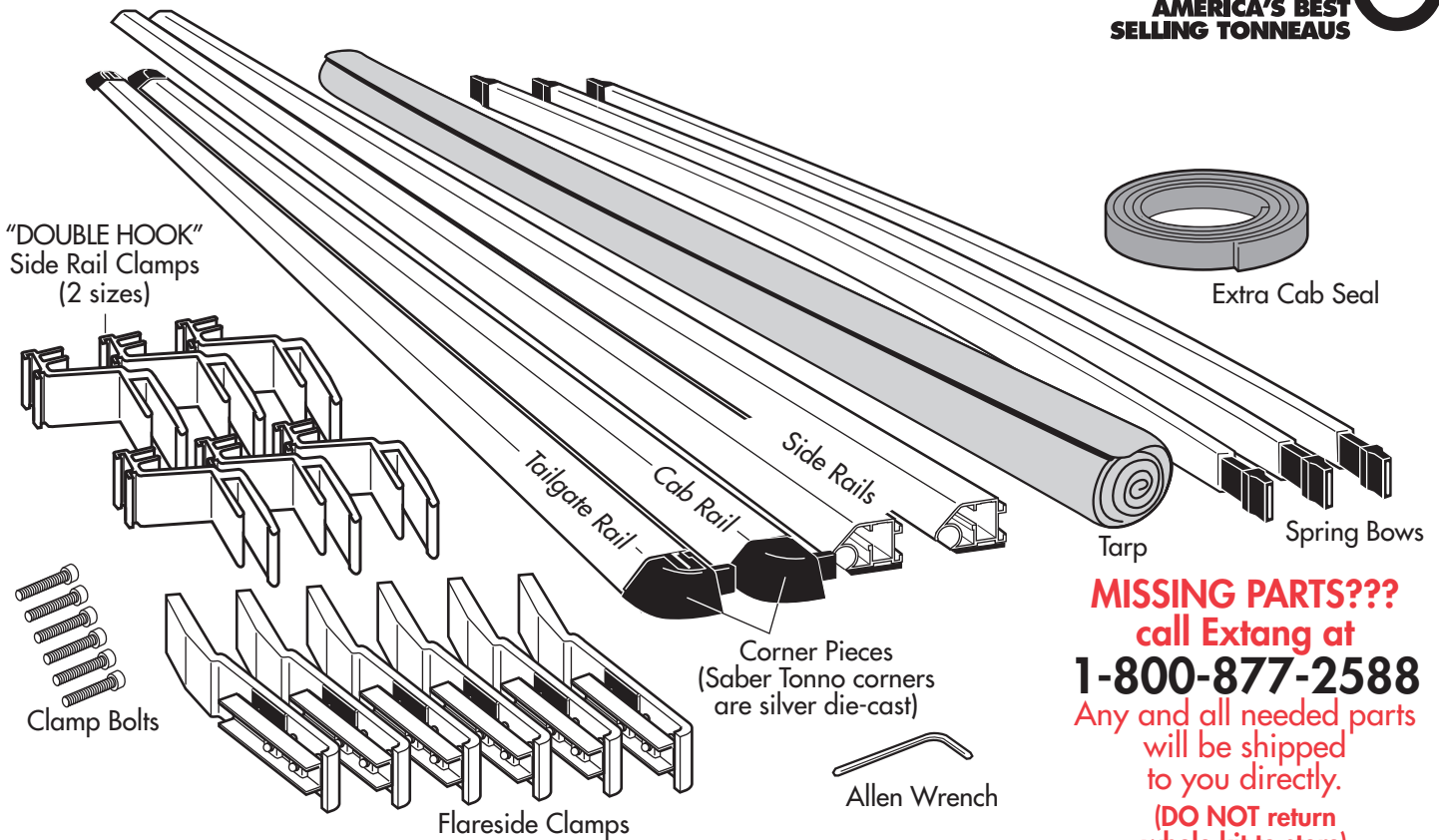

MISSING PARTS???
call Extang at
1-800-877-2588
Any and all needed parts
will be shipped
to you directly.
**(DO NOT return
whole kit to store)**

PARTS INCLUDED IN YOUR KIT. You may want to lay them out in this manner for accessibility.

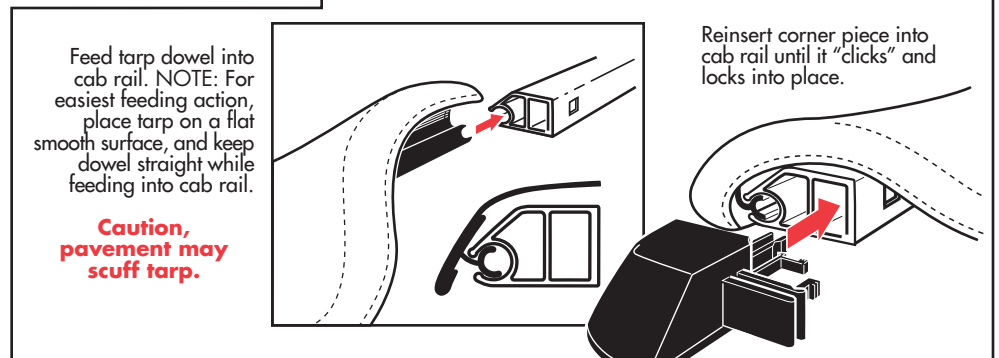
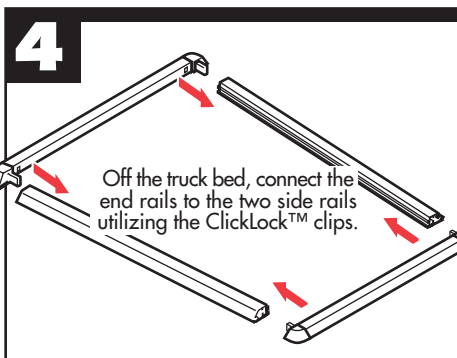
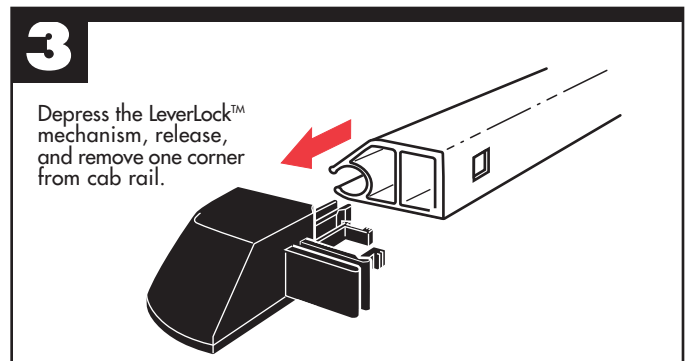

Extang Corporation
1901 E. Ellsworth Rd.
Ann Arbor, MI 48108
734 677-0444, Fax: 734 677-8409

Register your warranty at:
www.extang.com
Item No. 0145-0808 RH Printed in U.S.A.

5

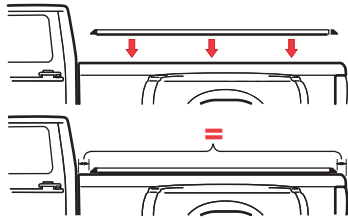

Place the rail assembly over the side of the truck box. Center rails evenly between cab and tailgate. (NOTE: Some applications have hard rubber risers (square rubber pad.) A riser must go toward tailgate. Some applications will have a riser at both ends, (most have no riser).

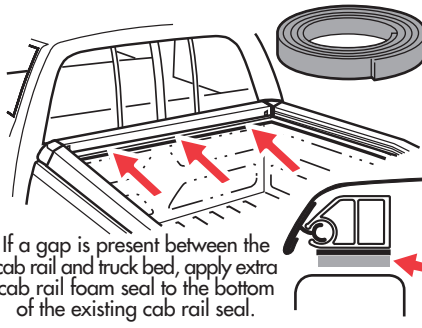

If a gap is present between the cab rail and truck bed, apply extra cab rail foam seal to the bottom of the existing cab rail seal.

For an OVER-THE-RAIL Bedliner

DIAGRAM A

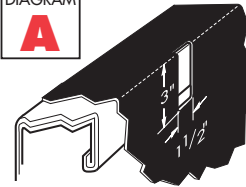
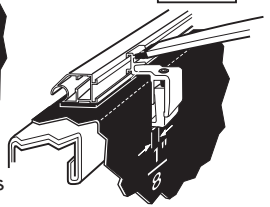

DIAGRAM B



For each clamp mark on your bedliner a 1-1/2" x 3" hole as shown above. Remove clamp. Cut holes in bedliner. Reinsert side rail clamp. Return to step 5.

Side rail clamped to bed with bow attached.

6

Note: For over-the-rail bed liners first refer to Diagrams A and B above.

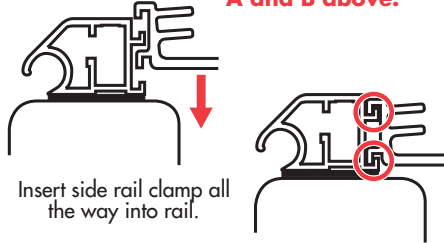

Insert side rail clamp all the way into rail.

Clamp Spacing (Same for each side) See the stickers located on each side rail for clamp position, or refer to the dimensions given below. Note: Use clamp intended for each position.—Remove stickers after installation.

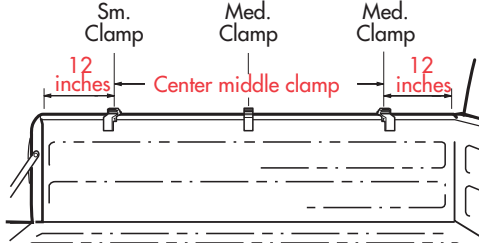

Place Clamp Here
STICKER

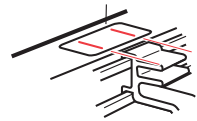

7

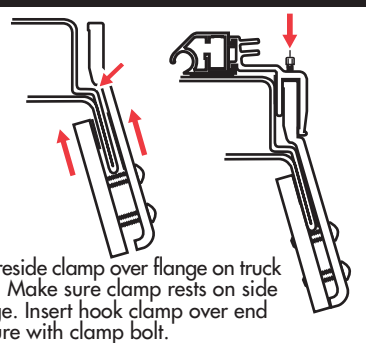

Insert flareside clamp over flange on truck sidewall. Make sure clamp rests on side wall ridge. Insert hook clamp over end and secure with clamp bolt.

8

Insert bow onto top or bottom peg. (Top peg for performance, Bottom for good looks.)

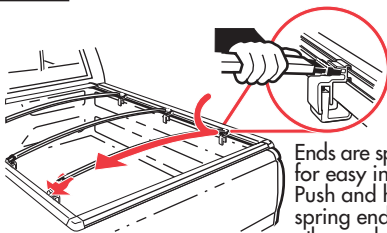

Ends are spring loaded for easy installation. Push and hold on spring end and let the other end slide on with the spring action.

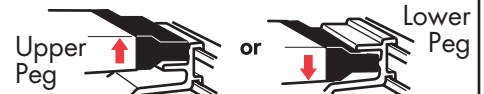

Upper Peg

Lower Peg

SPECIAL FEATURE: Two pegs offer two height adjustments.



Not
Do Not Place Between the Pegs

Note: Bow End does not fit between pegs.

9

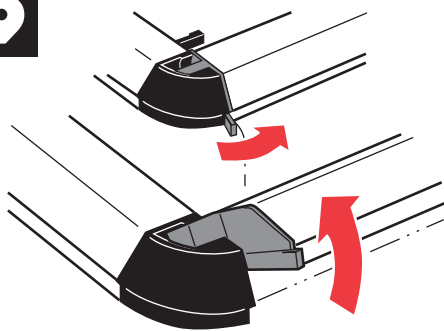

A. Release lever on both corners of tailgate rail and tilt rail up.

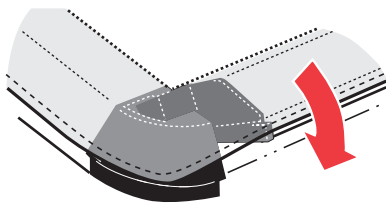

C. Close-up of downward rotation of rear rail. You will feel the "snap" effect and see it tighten snugly.

B. Attach tarp at front by pressing down on edge of tarp with the palms of your hands (about only 12 inches on each side). Then hook tarp to the tails rail's groove and click down to tighten tarp. See close-up.

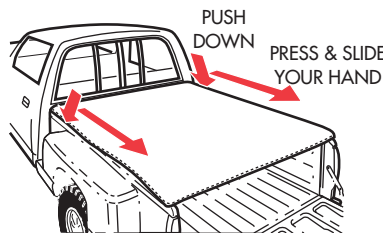
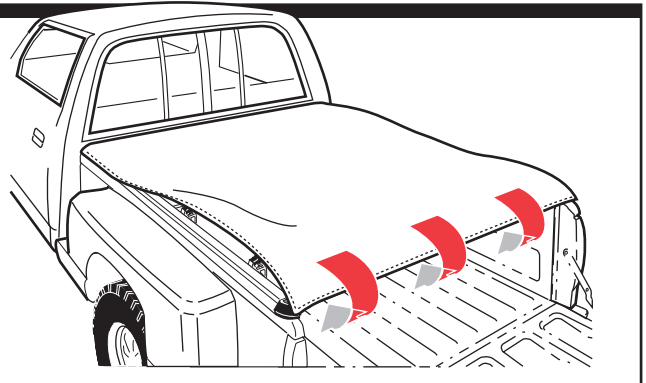

D. Finish attaching tarp along each side by pushing down and sliding your hand towards each corner. You can feel the "grip" action.

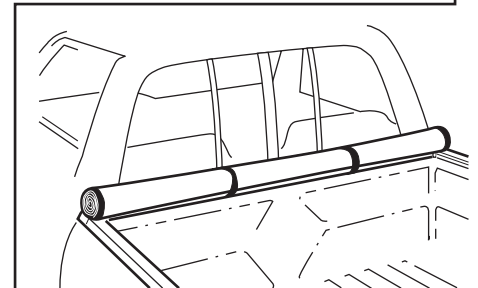

EASY USE OF TRUCK BED

Tarp may be rolled up and secured with Velcro® for bulk hauling